



**RANGO DE MODELOS DESDE
1 A 6 METROS CÚBICOS**

**RANGE OF MODELS FROM
1 TO 6 M³ OUTPUT**

- ❑ MDE1500
- ❑ MDE2250
- ❑ MDE3000
- ❑ MDE3000MOV
- ❑ MDE3750
- ❑ MDE4500
- ❑ MDE5250
- ❑ MDE6000
- ❑ MDE9000



- ❑ Máquinas de Alto Rendimiento diseñadas para el sector:
 - Hormigón
 - Grava / Cemento
- ❑ Resultados extraordinarios en Hormigón de alta granulometría.
- ❑ Dimensionado motor / reductor para 37 Kw por cada m³.
- ❑ Sistema manual de lubricación de rodamientos y cojinetes, (opcional: sistema automático) con una presión de trabajo superior a 250 bar.
- ❑ Sistema de Brazos y Palas de fundición especial antidesgaste, y de alta robustez.
- ❑ Forros interiores de 10 mm, también en la compuerta de descarga.



- ❑ High performance mixers specifically designed for the sectors:
 - Readymix Concrete
 - Chippings Cement
- ❑ Extraordinary results in high grain concretes
- ❑ Dimensioned reductor / motor for 37Kw for each m³.
- ❑ Manual bearing lubrication system, (optional: automatic system) with a work pressure over 250 bar.
- ❑ Arms an shovels system in special alloy steel, and high robustness.
- ❑ 10 mm lining, also in unloading lockgate.

MODELOS / MODELS		1500	2250	3000	3000 MOV	3750	4500	5250	6000	9000	
CAPACIDAD / DRY BATCH CAPACITY	Lt	1500	2250	3000	3000	3750	4500	5250	6000	9000	
HORMIGÓN POR CICLO / OUTPUT PER BATCH	M ³	1	1,5	2	2	2,5	3	3,5	4	6	
FUERZA MOTRIZ / DRIVE POWER	Kw	2x18,5	2x30	2x37	2x37	2x45	2x55	2x55	2x75	2x110	
BRAZOS MEZCLA / MIXING ARMS	Nº	6	8	8	14	12	12	12	14	16	
PESO DE MEZCLADORA / MIXER WEIGHT	Kg	4900	7000	8500	8000	8500	9200	11700	12500	19800	
GRANULOMETRIA / AGGREGATS SIZE	mm	De 0 a 120 mm 32 a 80 - 30% max. 80 a 100 - 10% max. 100 a 120 - 10% max.			De 0 a 150 mm 32 a 80 - 30% max. 80 a 100 - 10% max. 100 a 150 - 10% max.						
BRAZOS RASCADORES / SCRAPERS ARMS All models: 4				POTENCIA HIDRAULICO / HYDRAULIC POWER				3 KW			

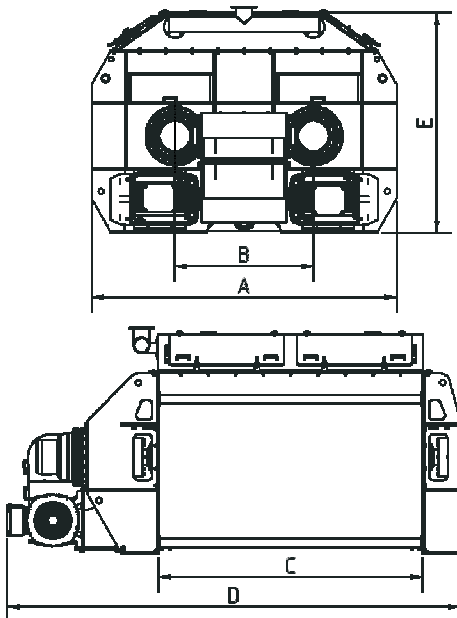



MODELOS / MODELS	MEDIDAS / MEASURES mm				
	A	B	C	D	E
MDE1500	2060	900	1024	2670	1585
MDE2250	2060	900	1348	2890	1585
MDE3000	2490	1120	1348	2950	1890
MDE3000MOV	2000	860	1962	3440	1695
MDE3750	2490	1120	1886	3720	1890
MDE4500	2490	1300	1886	3720	1890
MDE5250	2840	1300	1886	3720	2095
MDE6000	2840	1300	2200	4190	2095
MDE9000	3300	1500	2860	4910	2385

COMPLEMENTOS OPCIONALES / OPTIONALS COMPLEMENTS

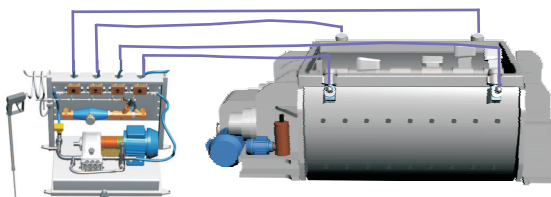

 SISTEMA DE LAVADO AUTOMÁTICO CICLO A CICLO MEDIANTE CABEZALES ROTATIVOS

 AUTOMATIC FLUSHING SYSTEM CYCLE TO CYCLE THROUGH ROTARY HEADS



 SISTEMA ENGRASE AUTOMATICO
 LUBRICATION AUTOMATIC SYSTEM



 SISTEMA DE DOBLE COMPUERTA
 DOUBLE DISCHARGE GATE SYSTEM



www.arcomet7.com

ARCOMET7 S.L.

Pol. Ind. Centrovía, C/ Buenos Aires, Nº12 - Nave A
50198 La Muela, Zaragoza (España)

TELF: +34 976 141873 FAX: +34 976 144763

 DELEGACIÓN
ZONA CATALUÑA
Tel. +34 619 70 36 20

 DELEGACIÓN
ZONA CENTRO
Tel. +34 680 980 628

 DELEGACIÓN
ZONA NORTE
Tel. +34 636 964 104

 ARLACO LDA.
Tel. +35.1227128279
www.arlaco.pt

www.arcomet7.com
arcomet7@arcomet7.com